

## Battery Vacuum Lifter VL 300

Developed for construction site use within the EU according to EN 13155



for lifting and transporting

### Description

- **increased safety via 2 independent vacuum circuits**
- each vacuum circuit is equipped with a vacuum tank with non-return valve, vacuum switch and control vacuum meter
- **2 completely closed vacuum circuits** prevent loss of vacuum at power failure
- acoustic signal indicates insufficient vacuum
- turning device and locking every 90°
- tilting device (0° until 90°) lock in vertical position
- **maximum structural depth approx. 190 mm**
- extendable at maximum by 4 extensions
- including protective hoods for the suction cups, to protect them when not in use

### Vacuum generation

- for battery operation with an external charger
- no cable - no hose

### Operation

- ON/OFF directly at the device
- SUCTION/RELEASE via hand valve at the device
- turning hand lever
- tilting hand lever

**Suspension:** crane eye at the carrying frame  
**Load capacity :** maximum 300 kg  
**Colour:** orange / partly galvanised

	vertical
	horizontal
	turning through +/- 360°
	tilting through 90°

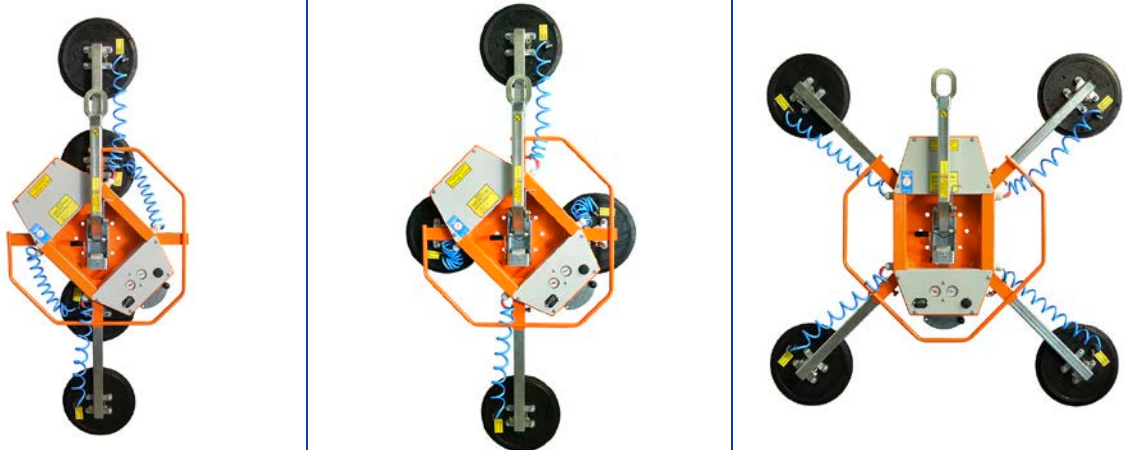
<b>suitable for lifting</b>	
material properties	gas-tight
surface	smooth
e.g.	glass panes, sealed units, window and curtain walling elements, plastic and ceramic plates, coated boards
<b>suction cup type</b>	<b>W300</b>
<b>diameter</b> in action approx. mm	300
<b>quality of suction cups</b>	black rubber abrasion possible
<b>number of suction cups</b>	2 x 2
<b>safe working load</b> on smooth and clean surface at -0.65 bar vacuum <b>at EC sites</b> kg	300
<b>outer distance of the suction cups</b> minimum approx. mm	700 x 700 300 x 1700
maximum approx. mm	1290 x 1290 860 x 1700
<b>dead weight</b> approx. kg	35 - 45
<b>distribution voltage</b> charger for battery	100 - 240 V / 47/63 Hz / 1 phase
<b>Item No.: VL 300...</b>	<b>control unit with manual valve control only</b>
	<b>control unit with radio remote control</b>
<b>Item No.: VL 300...</b>	<b>FFB</b>
<b>Accessories on request</b>	
<b>Item No.: opt-AbB-HV</b>	blow-off function for quicker release of the vacuum lifter (manual valve control only)
<b>Item No.: opt-AbB-FB</b>	blow-off function for quicker release of the vacuum lifter (remote control only)
<b>Item No.: opt-lvsAufh</b>	suspension bar with 5-fold locking (0° / 22,5° / 45° / 67,5° / 90°)
<b>Item No.: ZB-TK-800</b>	aluminum transport box with plastic lid for Vacuum Lifter VL 300
	

## Vacuum Lifter VL 300 for 300 kg with 4 suction cups

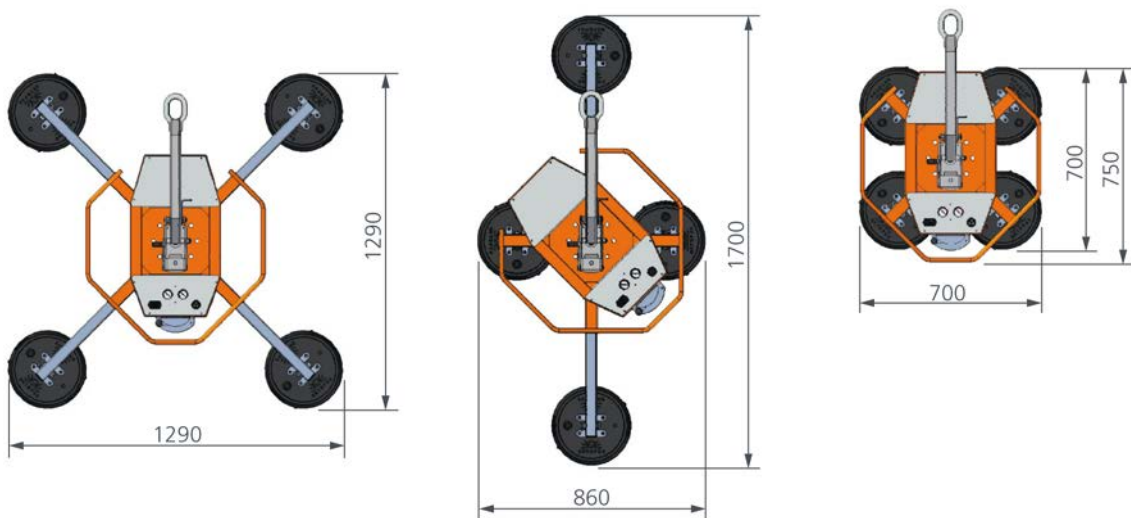
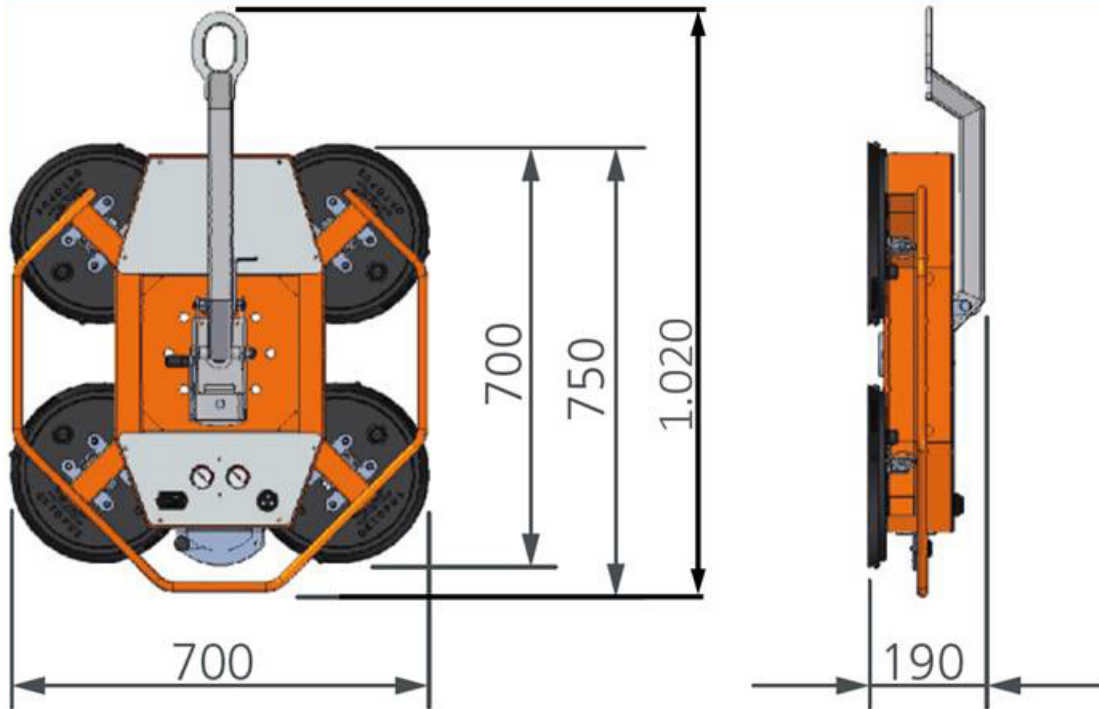

suspension bar with lock every 22,5°

