

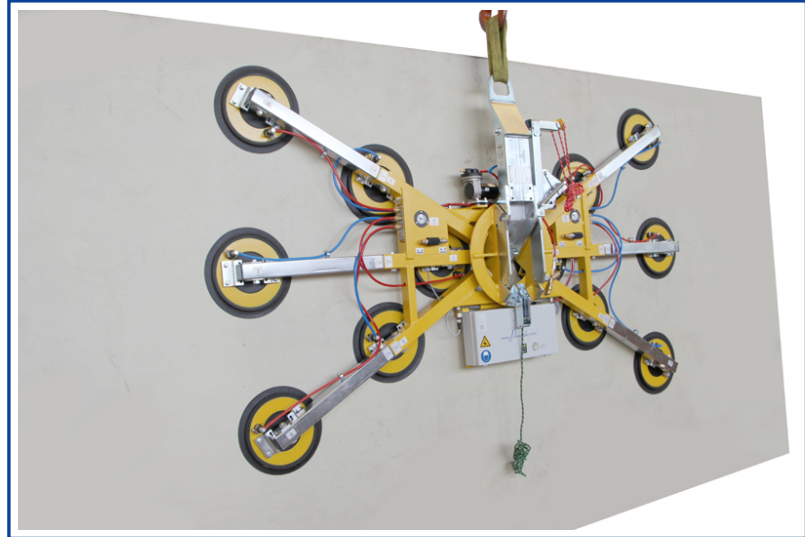



Accu-Device Kombi 7211-DS4Z-20

Developed for construction
site use within the EU
according to EN 13155



	vertical
	horizontal
	turning through +/- 360°
	tilting through 90°

Description

- **increased safety via 2 independent vacuum circuits**
- each vacuum circuit is equipped with a vacuum tank with non-return valve, vacuum switch and control vacuum meter
- **2 completely closed vacuum circuits**
prevent loss of vacuum at power failure
- acoustic signal indicates insufficient vacuum
- extendable to 2 x 6 suction cups
- all suction cups lockable individually
- turning device with roller bearings and locking every 90°
- tilting device (0° to 90°) with locking device every 3°
- **maximum structural depth 230 mm**
- extendable at maximum by 6 extensions

Vacuum generation

- for battery operation with quick-change device for short battery change times of less than one minute
- battery charger for charging second battery
- no cable - no hose

Operation

- ON/OFF directly at the device
- SUCTION/RELEASE via hand valve at the device
- turning tackle
- TILTING tackle

Suspension: crane eye at the carrying frame

Load capacity : 300 kg / 600 kg

Colour: yellow / partly zinked

suitable for lifting				
material properties	gas-tight			
surface	smooth			
e.g.	glass panes, sealed units, window and curtain walling elements, plastic and ceramic plates, coated boards			
suction cup type	388			
diameter in action approx. mm	300			
quality of suction cups	black rubber abrasion possible up to 80° C heat resistant from 4 mm glass thickness			
number of suction cups	2 x 6	2 x 5	2 x 4	2 x 3
number of extensions	6	4	2	0
safe working load on smooth and clean surface at 60 % vacuum				
at EC sites kg	600	500	400	300
in-company kg	600	600	600	600
outer distance of the suction cups approx. mm	2270 x 1360	2150 x 1360	2270 x 860	1270 x 860
dead weight approx. kg	109	95	87	81
distribution voltage charger for battery	110 - 230 V / 50/60 Hz / 1 phase			
Item No.: 7211-DS4Z-20...	-12	-10	-08	-06
Accessories on request				
Item No.: 388-SCHUTZ	protection cap for suction cup 388			
Item No.: 7003-KA4&6	mountable short suspension eye for Kombi 7011-DS4-2012 / 7211-DS4-2012			
Item No.: 7003-GTWDS4	transport carriage for Kombi 7011-DS4-2012 / 7211-DS4-2012			
Item No.: 7003-WSPDS4	rain cover for transport carriage including Kombi 7211-DS4-2012			
Item No.: Balance 17	counterweight unit - supernatant 1.5m - weight 600kg - motor-driven			
Item No.: Balance 18	counterweight unit - supernatant 0.7 m - weight 400kg - manual			

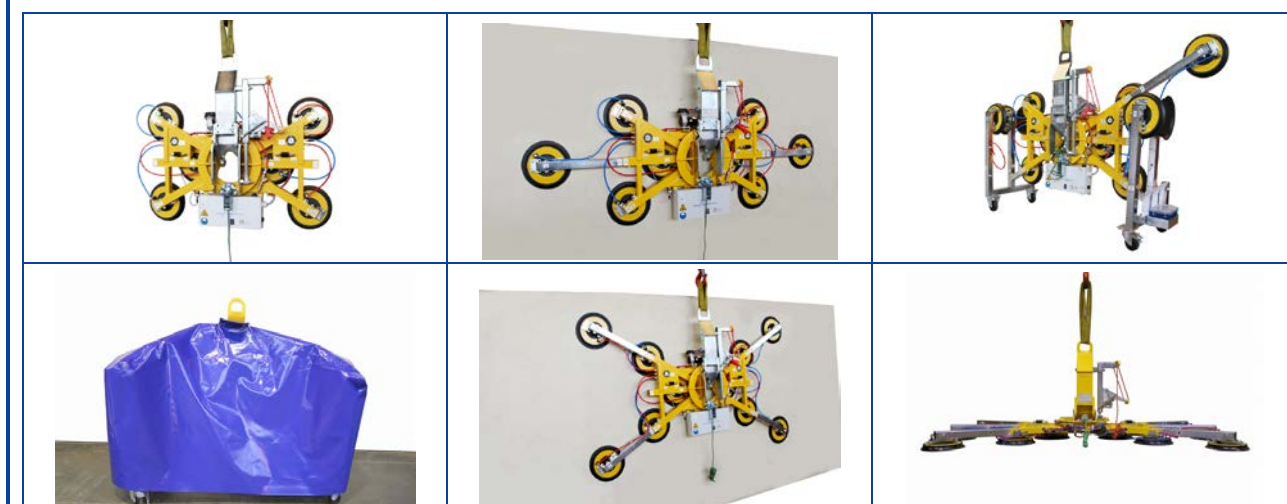

Kombi 7211-DS4Z-20 with suction cups 388

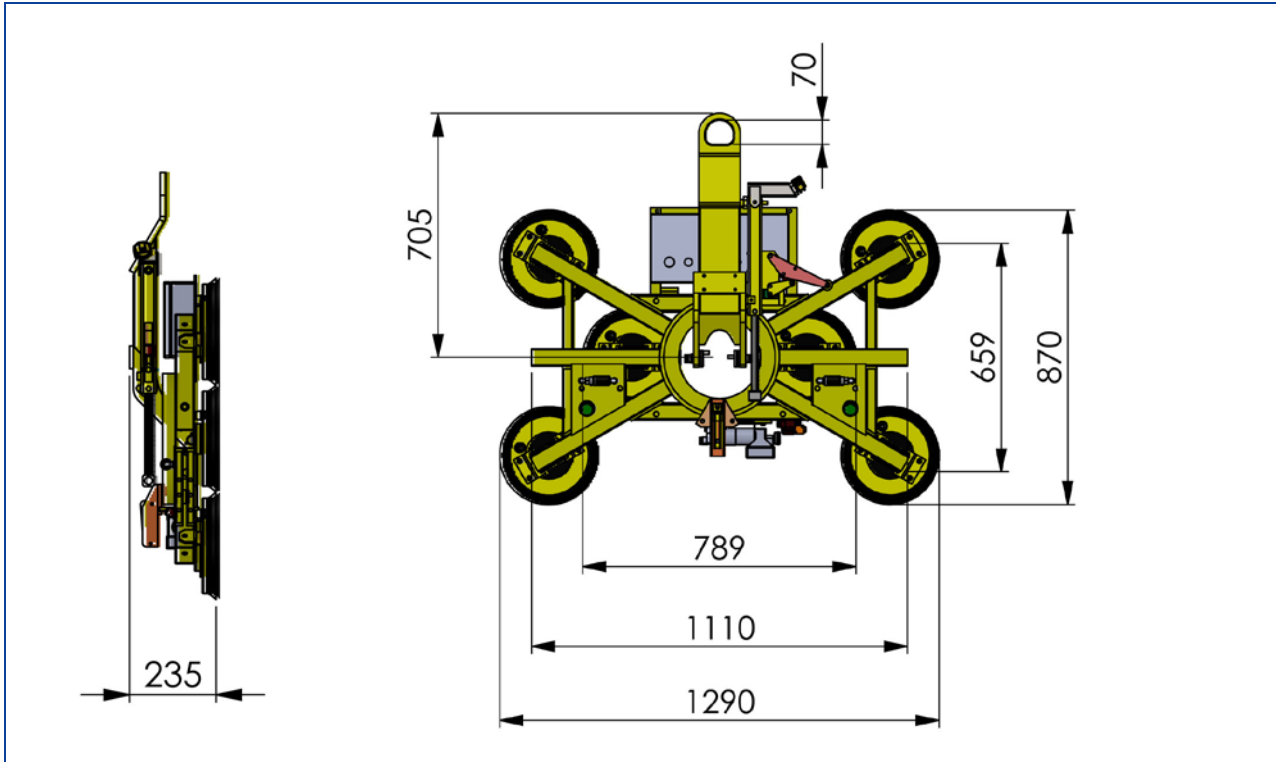

Kombi 7211-DS4Z-20 with suction cups 388 and 2 extensions

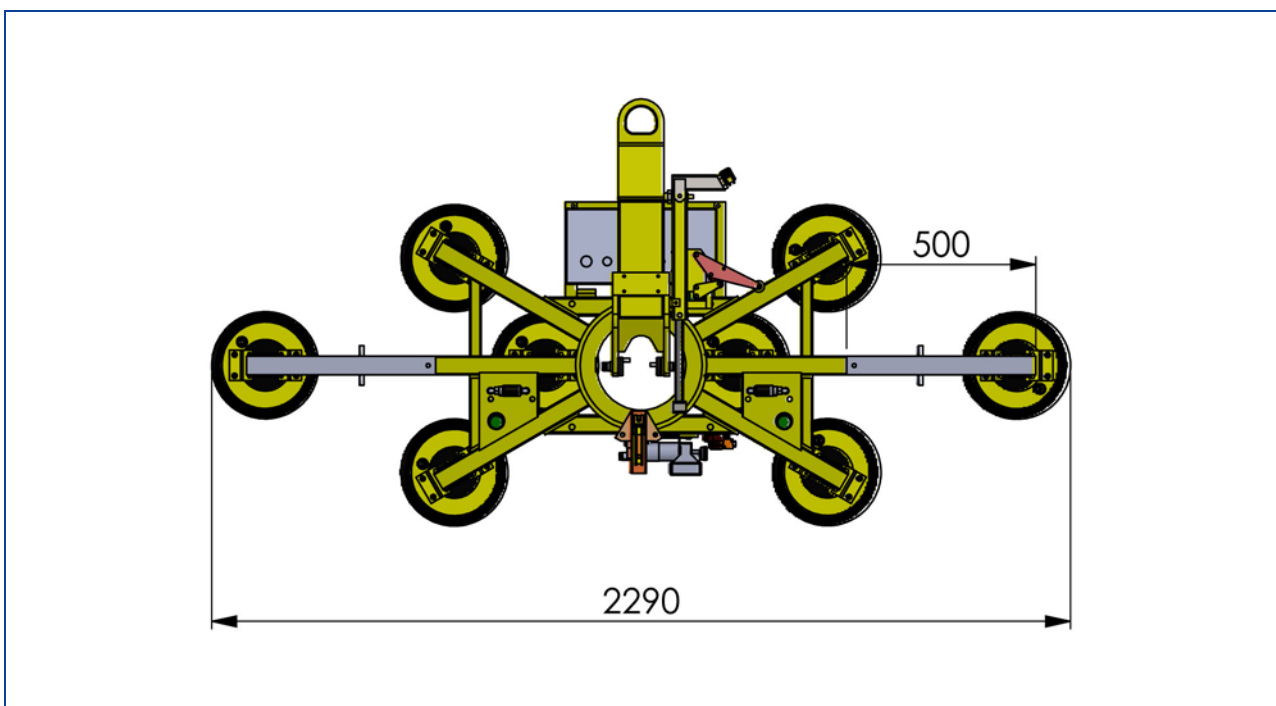

Kombi 7211-DS4Z-20 with suction cups 388 and 4 extensions

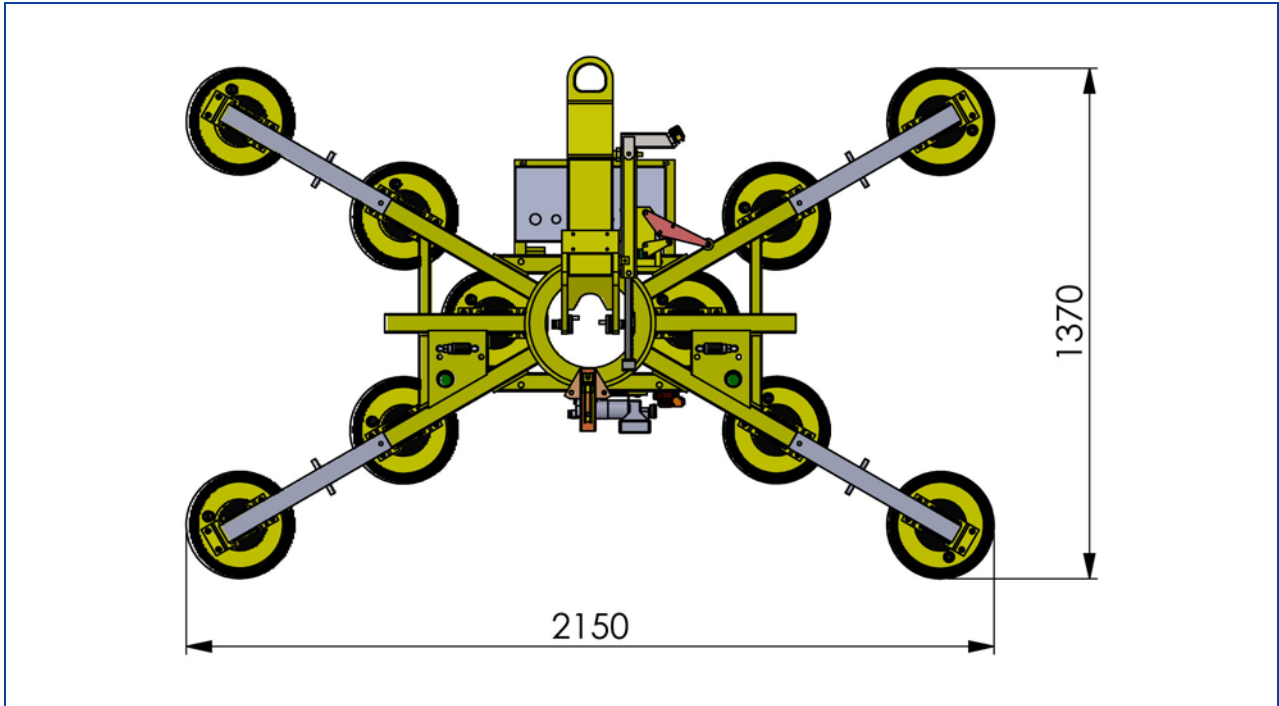

Kombi 7211-DS4Z-20 with suction cups 388 and 6 extensions

