

Manipulation Device 7025-MD4-2/E

Single circuit Vacuum Lifting
Device according to EN
13155

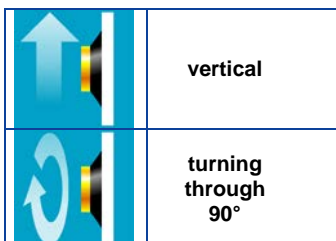

Description

- **1 circuit vacuum system**
- the vacuum circuit has a vacuum tank with nonreturn valve, vacuum switch and control vacuum meter
- **completely closed vacuum circuit**
prevents loss of vacuum at compressed air failure
- **power failure monitoring system**
- acoustic signal
reports insufficient vacuum/drop in air pressure
- single-row layout of the suction cups
- distance of suction cups can be adjusted
- suction cup lockable
- stepless turning through 90°
with pneumatic cylinder
- height-adjustable operating handle
- holder for crane switch

Vacuum generation

- via built-in suction jet (Venturi)
for operation at least 6 bars compressed air are necessary
- optional air pressure switching
- optional quick-release function

Operation

- | | |
|-----------|------------------------|
| • ON/OFF | directly at the device |
| • SUCTION | via a touch valve |
| • RELEASE | via two touch valves |
| • TURNING | via two touch valves |

Suspension: crane eye at the carrying frame
Load capacity : **200kg/250kg**
Colour: yellow / partly zinked

suitable for lifting		
material properties	gas-tight	
surface	smooth	
e.g.	glass panes, sealed units, window and curtain walling elements, plastic and ceramic plates, coated boards	
suction cup type	488-K	388
diameter in action approx. mm	350	300
quality of suction cups	rubber red abrasion possible up to 80° C heat resistant from 3 mm glass thickness	black rubber abrasion possible up to 80° C heat resistant from 4 mm glass thickness
number of suction cups	2	2
safe working load on smooth and clean surface at 60 % vacuum in-company kg	250	200
outer distance of the suction cups min approx. max. approx. min. with enlargement set approx. max. with enlargement set approx.	790 x 350 mm 1560 x 350 mm 800 x 680 mm 1460 x 680 mm	750 x 300 mm 1520 x 300 mm 800 x 680 mm 1460 x 680 mm
dead weight approx. kg		
air pressure connection	9 mm	
Item No.: 7025-MD4-2/E...	488	388
Accessories on request		
Item No.: OPT-DLSpar	air pressure saving switching – saves approx. 50% of the air pressure consumption	
Item No.: OPT-SLF	quick-release function – with full pressure supply	
Item No.: OPT-388TR	device equipped with : mark-free suction cups for coated glass	
Item No.: OPT-388K	device equipped with : softer suction cup for thinner glass	
Item No.: 7003-ASH5075	spacer for suction cup holder - 50 mm or 75 mm more distance	
Item No.: 7003-VB4-2	enlargement set (2 pieces)	



Vacuum Lifter 7025-MD4-2/E with suction cups 388

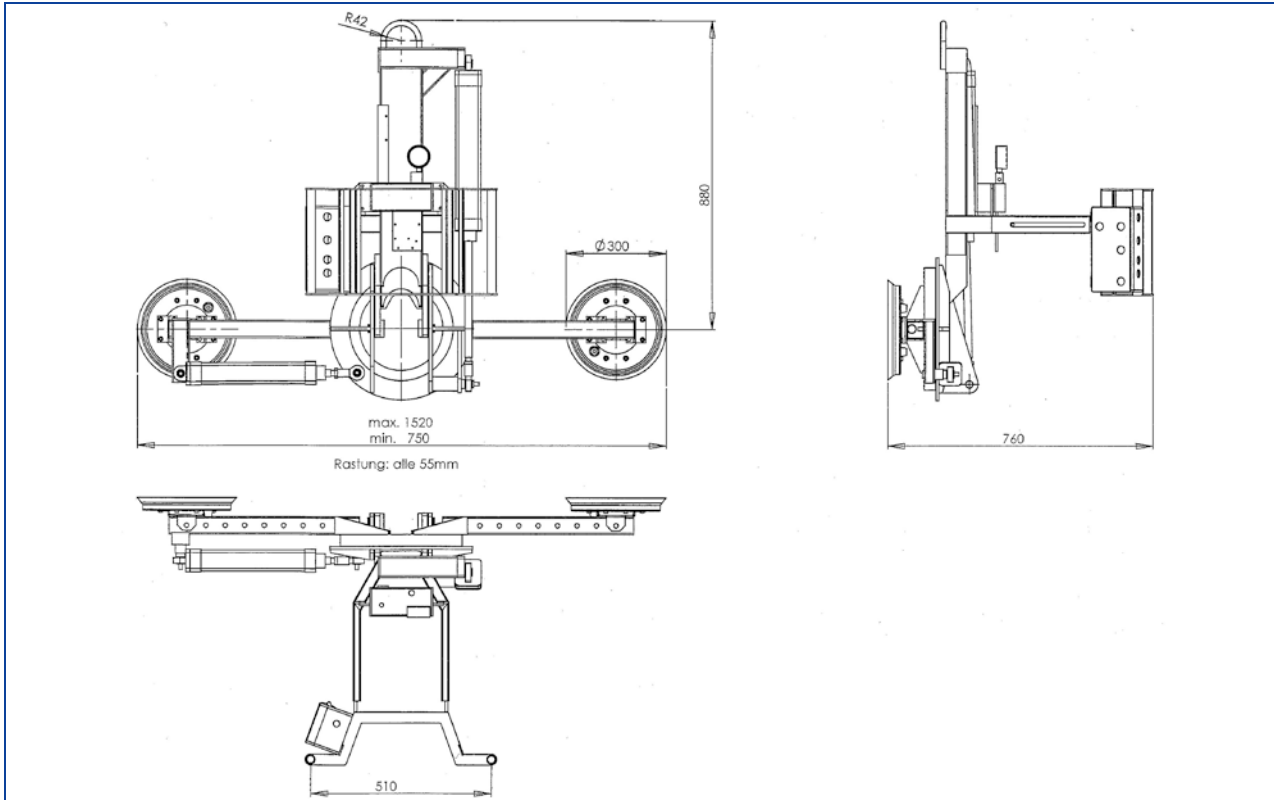

Vacuum Lifter 7025-MD4-2/E with suction cups 488

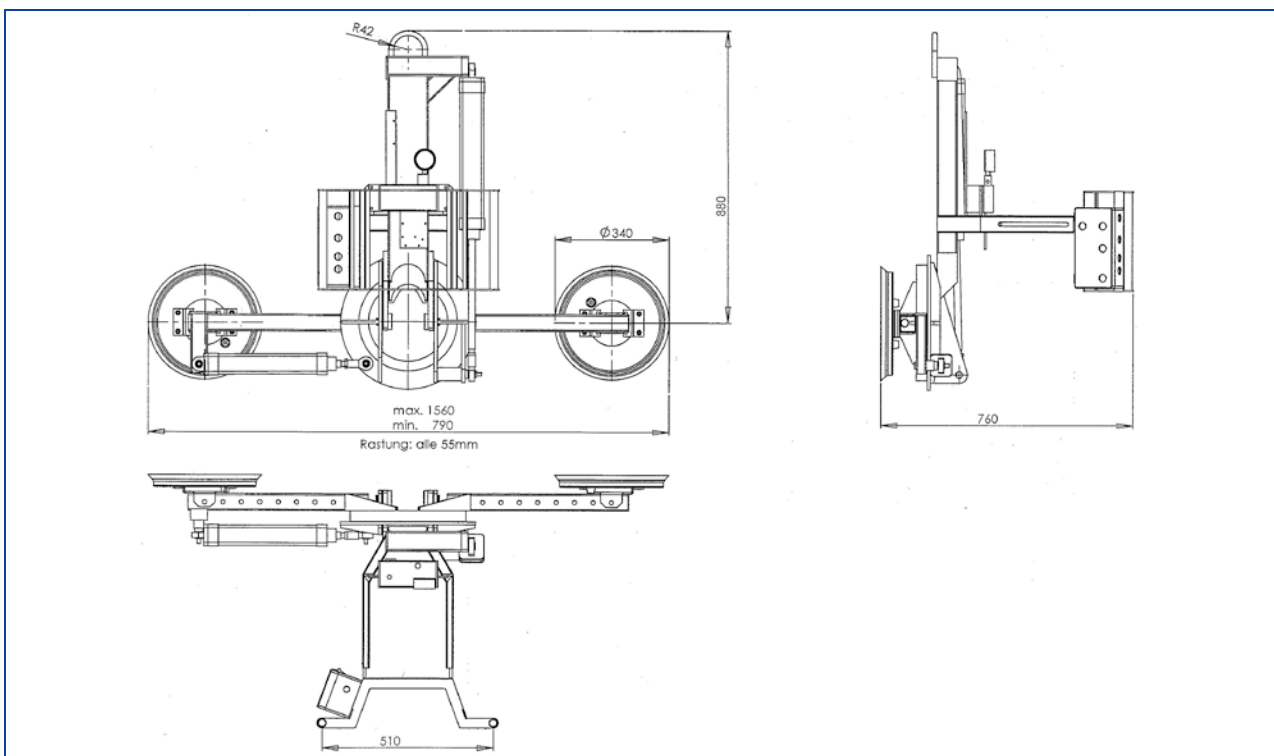

Vacuum Lifter 7025-MD4-2/E with enlargement set 7003-VB-4-2

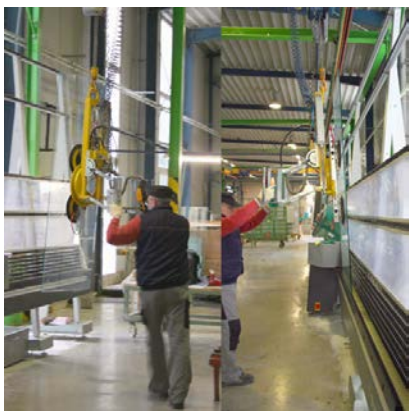
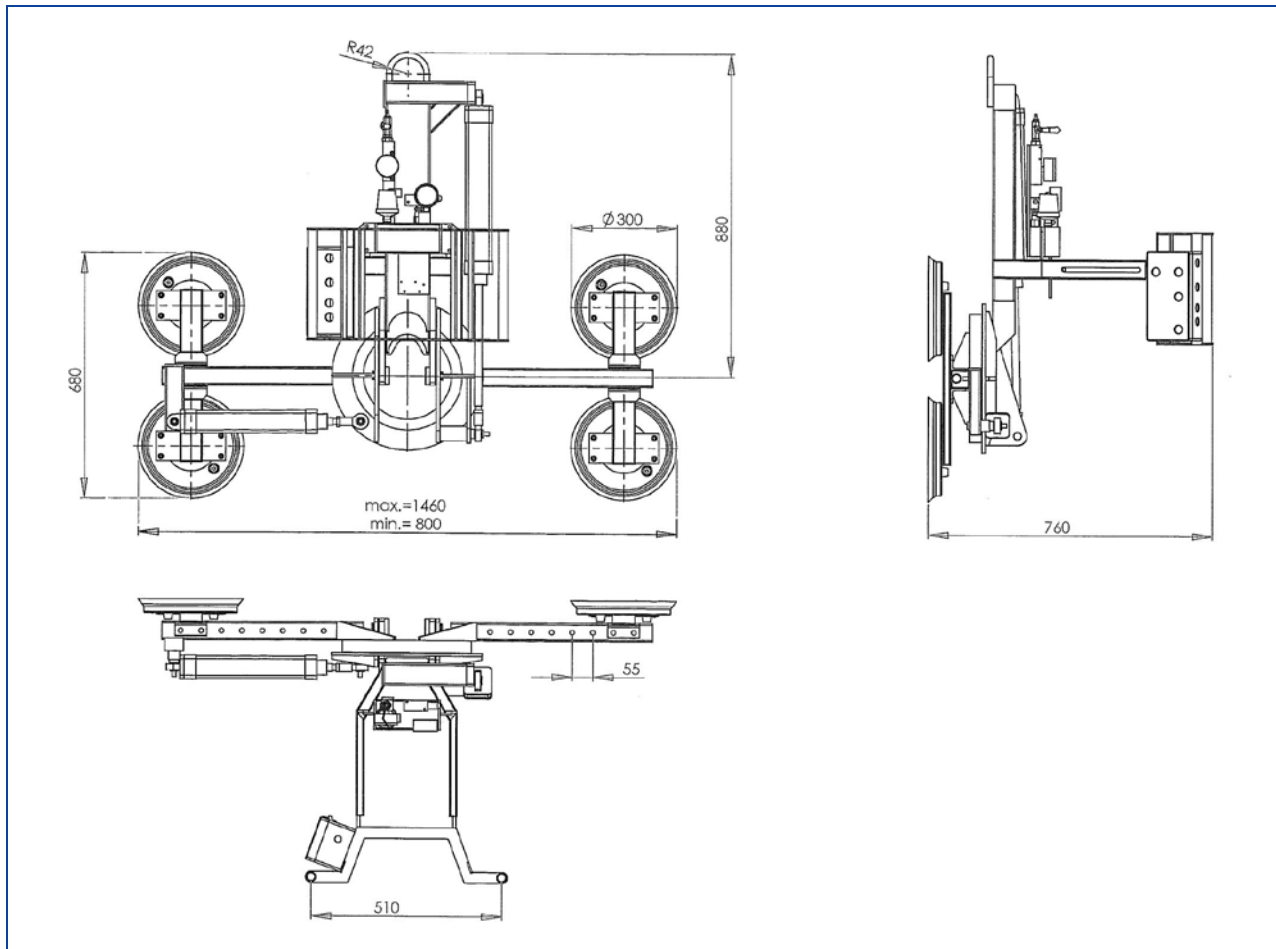

Do you want to learn more?

Use the QR code for the video and you will also learn more about the device.

Or click on the picture.

**Vacuum Lifter 7025-MD2/E
in use at the glass grinding shop.**