

## Vacuum Lifter 7025-MD2-4

Single circuit Vacuum Lifting  
Device according to EN  
13155

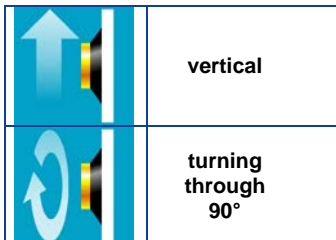
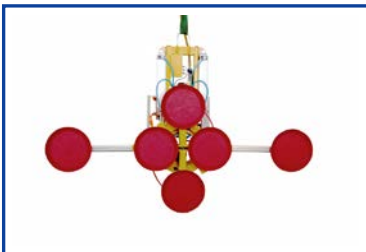
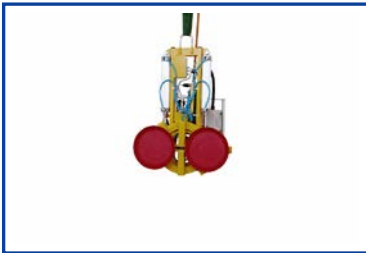

### Description

- **1 circuit vacuum system**
- the vacuum circuit has a vacuum tank with nonreturn valve, vacuum switch and control vacuum meter
- **completely closed vacuum circuit**  
prevents loss of vacuum at compressed air failure
- **power failure monitoring system**
- acoustic signal  
reports insufficient vacuum/drop in air pressure
- Basic expansion level: Single-row layout of the suction cups, this can be extended quickly and easily using 2 extension sets
- stepless turning through 90°  
with pneumatic cylinder
- holder for crane switch
- height-adjustable guide handle

### Vacuum generation

- via built-in suction jet (Venturi)  
for operation at least 6 bars compressed air are necessary
- optional air pressure switching
- optional quick-release function

### Operation

- |           |                        |
|-----------|------------------------|
| • ON/OFF  | directly at the device |
| • SUCTION | via a touch valve      |
| • RELEASE | via two touch valves   |
| • TURNING | via two touch valves   |

**Suspension:** crane eye at the carrying frame  
**Load capacity :** 200 kg until 400 kg / 250 kg until 500 kg  
**Colour:** yellow / partly zinked

|  |   |           |            |  |           |            |
|--|---|-----------|------------|--|-----------|------------|
| <b>suitable for lifting</b>  |   |           |            |  |           |            |
| material properties  | gas-tight   |           |            |  |           |            |
| surface  | smooth  |           |            |  |           |            |
| e.g.   | glass panes, sealed units, window and curtain walling elements, plastic and ceramic plates, coated boards |           |            |  |           |            |
| <b>suction cup type</b>  | <b>488-K</b>  |           |            | <b>388</b>   |           |            |
| <b>diameter</b>  |   |           |            |  |           |            |
| in action approx. mm   | 350   |           |            | 300  |           |            |
| <b>quality of suction cups</b>   | rubber red<br>abrasion possible<br>up to 80° C heat resistant<br>from 3 mm glass thickness                |           |            | black rubber<br>abrasion possible<br>up to 80° C heat resistant<br>from 4 mm glass thickness |           |            |
| <b>number of suction cups</b>  | 2   | 4         | 6          | 2  | 4         | 6          |
| <b>number of extensions</b>  | 0   | 2         | 4          | 0  | 4         | 6          |
| <b>safe working load</b><br>on smooth and clean<br>surface<br>at 60 % vacuum |   |           |            |  |           |            |
| <b>in-company</b> kg   | 250   | 500       | 500        | 200  | 400       | 400        |
| <b>outer distance of the suction cups</b>                                    |   |           |            |  |           |            |
| approx. mm   | 740 x 350   | 740 x 980 | 1990 x 980 | 650 x 300  | 650 x 830 | 1220 x 830 |
| <b>dead weight</b> approx. kg  | 55  |           | 76         | 53   |           | 72         |
| <b>air pressure connection</b>   | 9 mm  |           |            |  |           |            |
| <b>Item No.: 7025-MD2-4...</b>   | <b>488</b>  |           |            | <b>388</b>   |           |            |
| <b>Accessories on request</b>  |   |           |            |  |           |            |
| <b>Item No.: OPT-DLSpar</b>  | air pressure saving switching – saves approx. 50% of the air pressure consumption                         |           |            |  |           |            |
| <b>Item No.: OPT-SLF</b>   | quick-release function – with full pressure supply  |           |            |  |           |            |
| <b>Item No.: OPT-WG-Me</b>   | optical warning device instead of an acoustic warning device  |           |            |  |           |            |
| <b>Item No.: OPT-388TR</b>   | device equipped with : mark-free suction cups for coated glass  |           |            |  |           |            |
| <b>Item No.: OPT-388K</b>  | device equipped with : softer suction cup for thinner glass   |           |            |  |           |            |

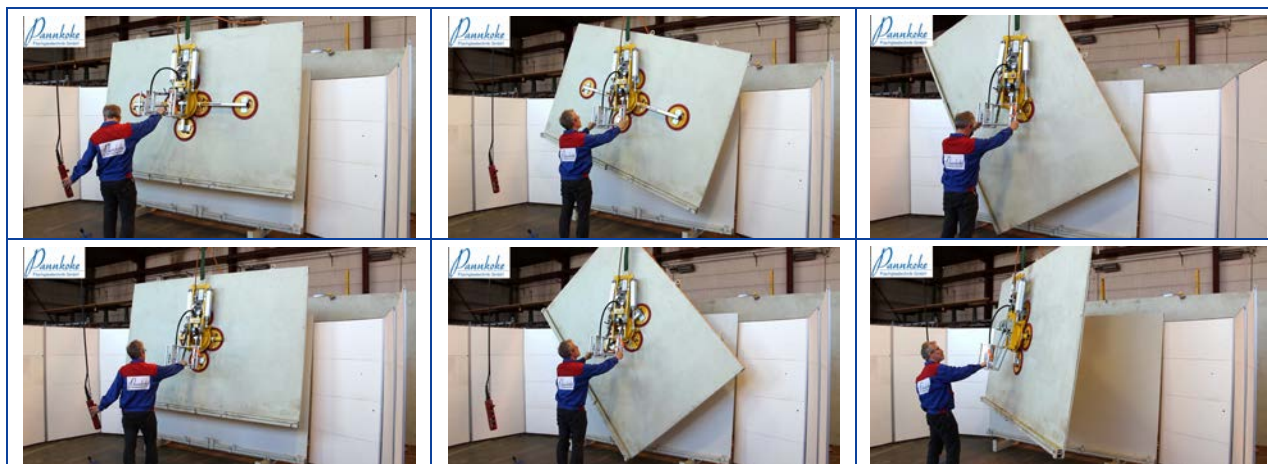

## Vakuum Lifter 7025-MD2-4 with suction cup 388

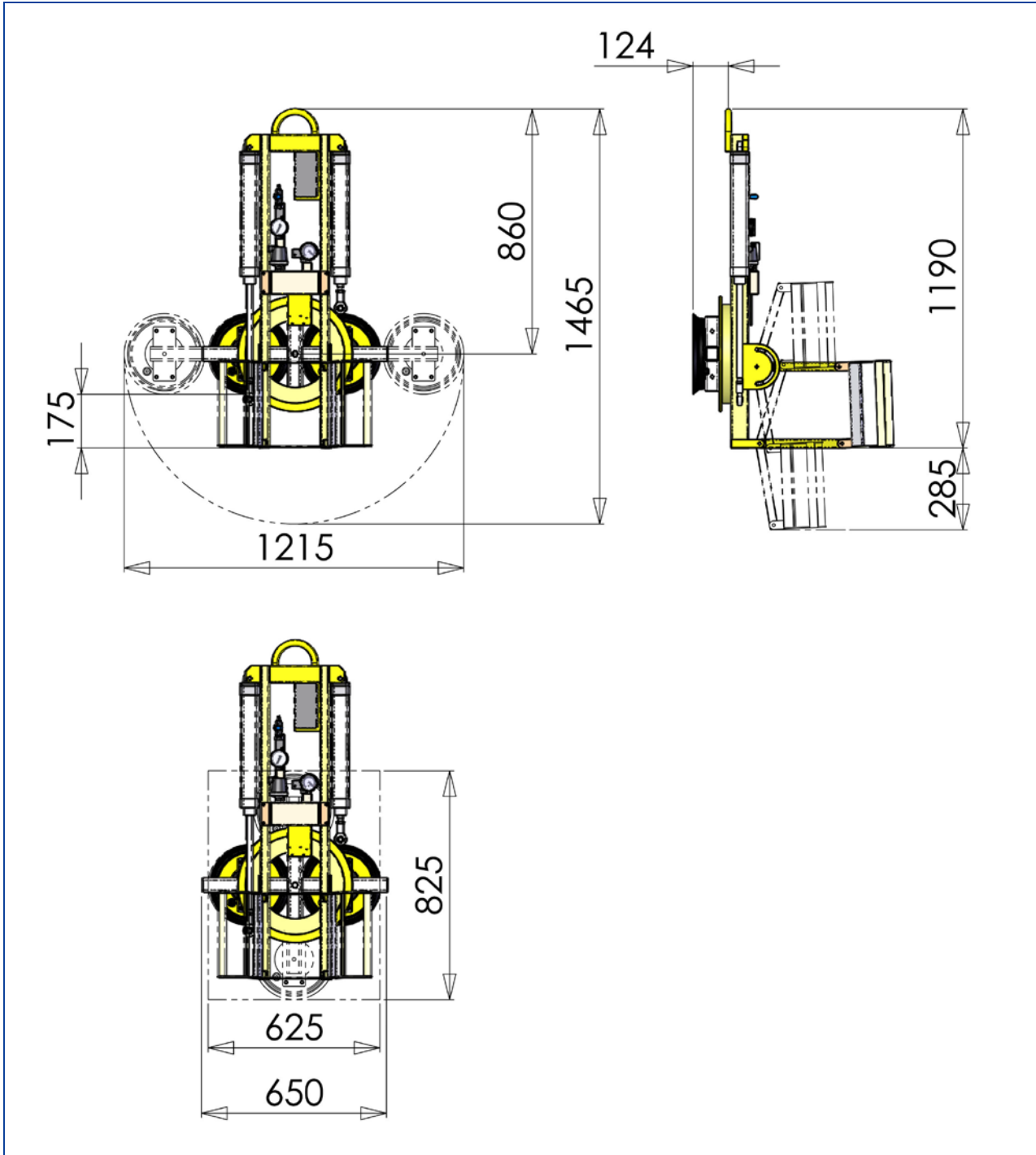

## Vacuum Lifter 7025-MD2/E with suction cups 488

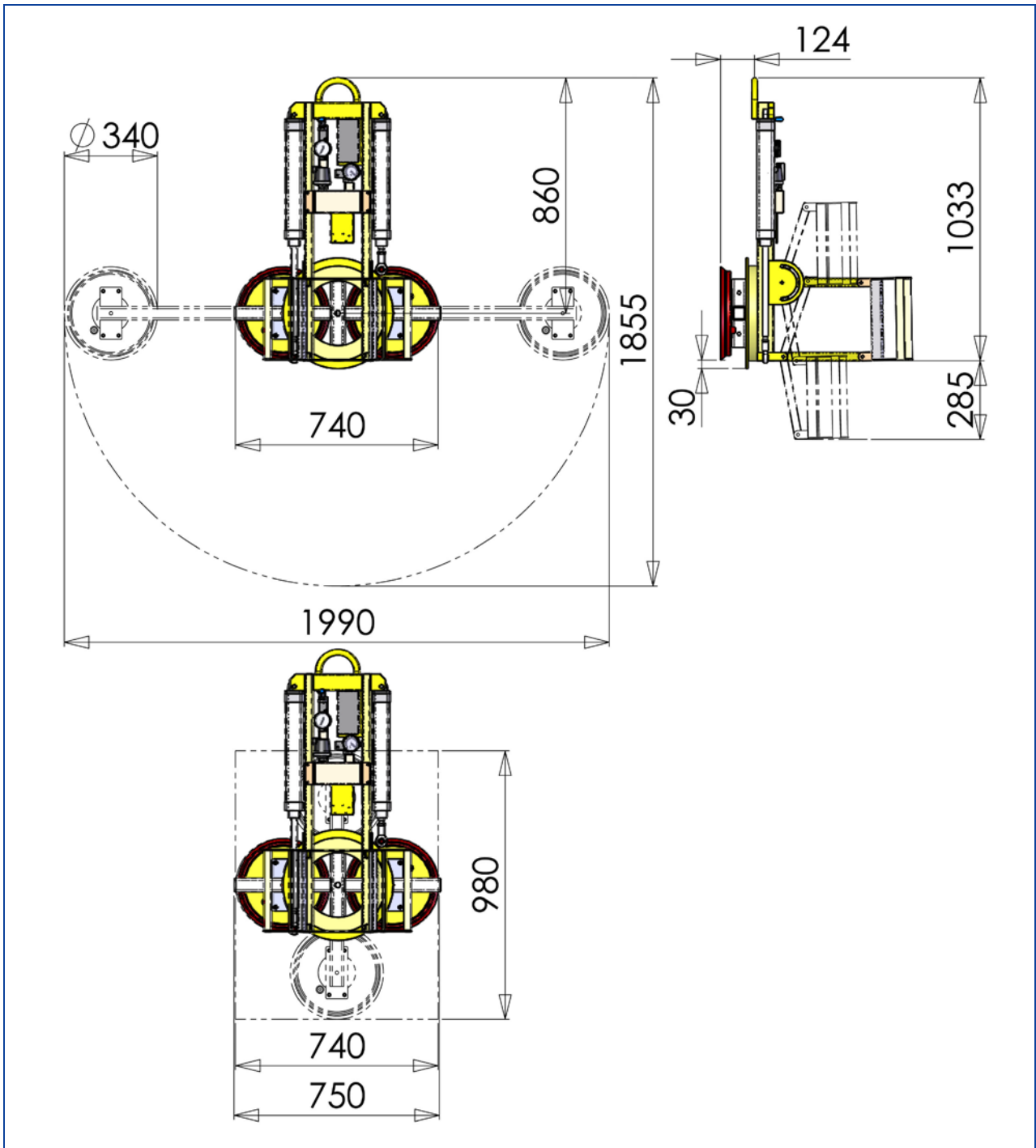

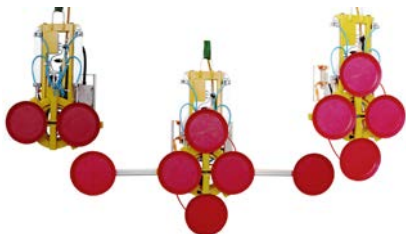

**Do you want to learn more?**

**Use the QR code to view the video and to learn more about the device.**

**Or click on the picture.**

**Vacuum lifter 7025-MD2-4  
in a functional test.**

