

Manipulation Device 7025-C-1000/E

**1-circuit vacuum lifting
device according to
EN 13155**

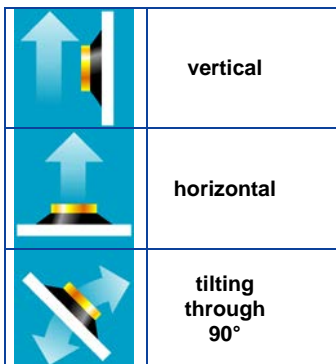

Description

- **1 circuit vacuum system**
- the vacuum circuit has a vacuum tank with non-return valve, vacuum switch and control vacuum meter
- **completely closed vacuum circuit**
prevents loss of vacuum at compressed air failure
- **power failure monitoring system**
- acoustic signal
reports insufficient vacuum/drop in air pressure
- all suction cups lockable individually
- stepless tilting through 90°
with pneumatic cylinder
- length adjustable operating handle
- holder for crane switch

Vacuum generation

- via built-in suction jet (Venturi)
for operation at least 6 bars compressed air are necessary
- optional air pressure switching
- optional quick-release function

Operation

- ON/OFF directly at the device
- SUCTION via a touch valve
- RELEASE via two touch valves
- TILTING via two touch valves

Suspension: crane eye at the carrying frame

Load capacity : up to 1000 kg

Colour: yellow / partly zinked

suitable for lifting			
material properties	gas-tight		
surface	smooth		
e. g.	glass panes, sealed units, window and curtain walling elements, plastic and ceramic plates, coated boards		
suction cup type	488-K	388	
diameter in action approx. mm	350	300	
quality of suction cups	rubber red abrasion possible up to 80° C heat resistant from 3 mm glass thickness	black rubber abrasion possible up to 80° C heat resistant from 4 mm glass thickness	
number of suction cups	8	18	
safe working load on smooth and clean surface at 60 % vacuum			
in-company kg	900	700	1000
dead weight approx. kg			
air pressure connection	9 mm		
Item No.: 7025-C-1000-07/E...	8-4	8-3	12-3
Accessories on request			
Item No.: OPT-DLSpar	air pressure saving switching – saves approx. 50% of the air pressure consumption		
Item No.: OPT-SLF	quick-release function – with full pressure supply		
Item No.: OPT-388TR	device equipped with : mark-free suction cups for coated glass		
Item No.: OPT-388K	device equipped with : softer suction cup for thinner glass		

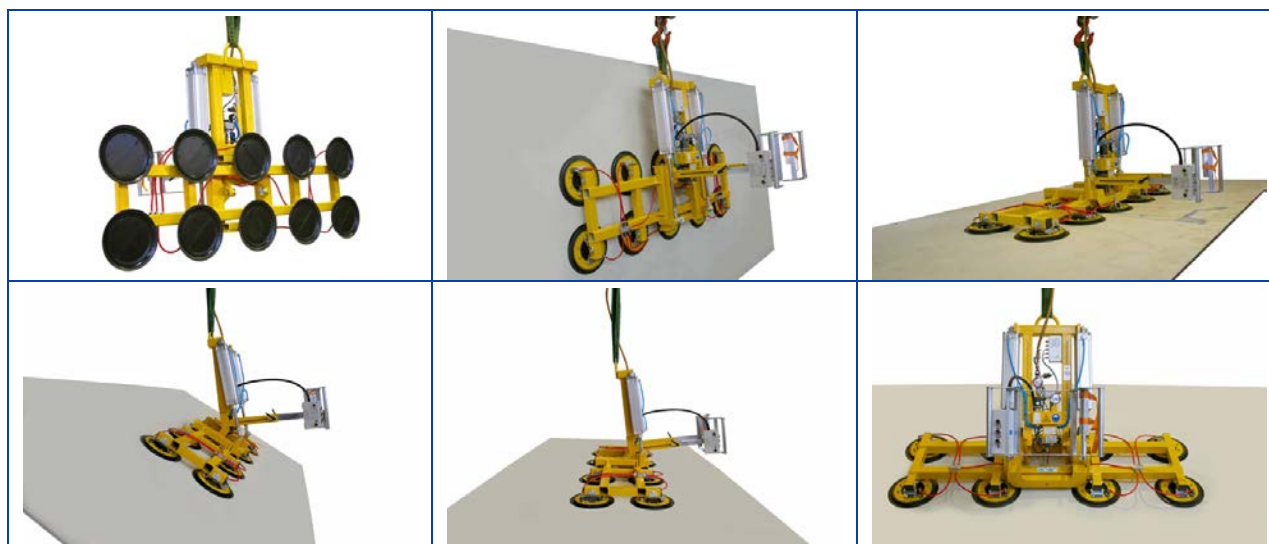

Manipulation Device 7025-C-1000/E with 8 suction cups 388

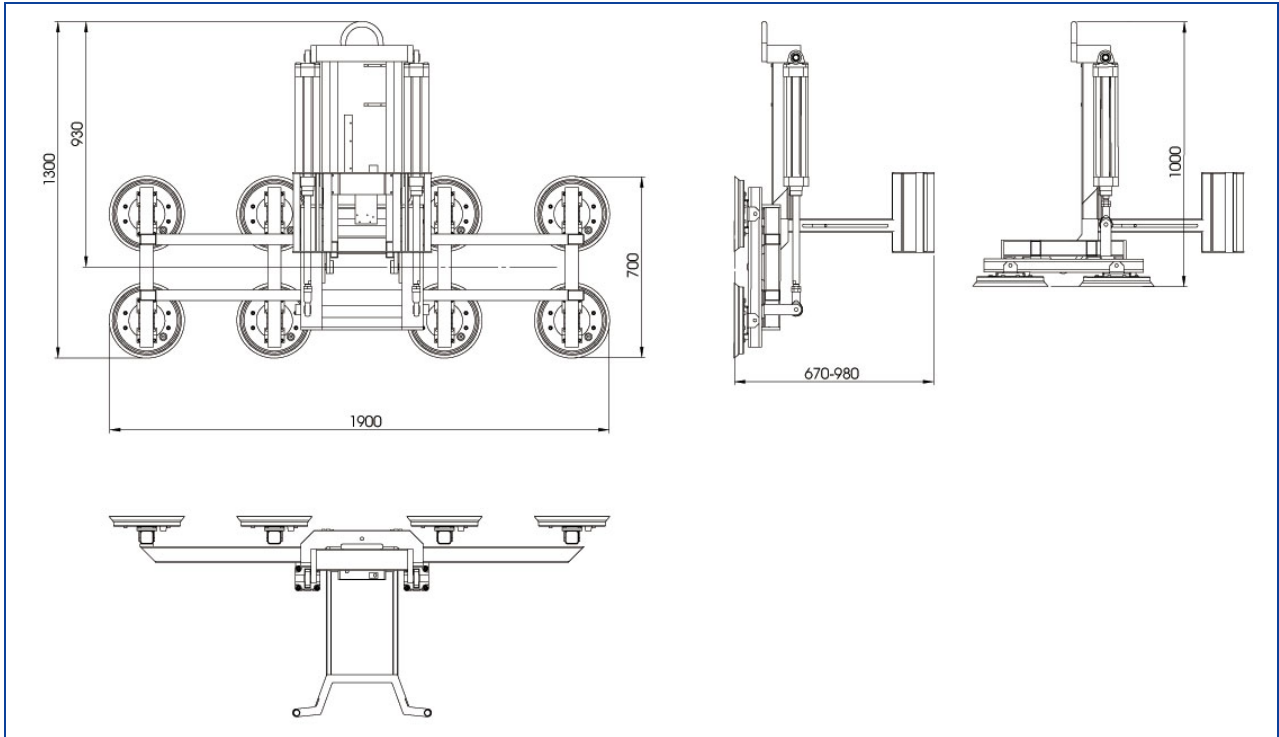

Do you want to learn more?

Use the QR code to see more operation photos and learn about the device.

Or click on the picture.

**Vacuum lifter 7025-C-1000
in use at the glass processing.**

