

Accu-Device Kombi 7011-AB-2012

for intra-plant use according
to EN 13155

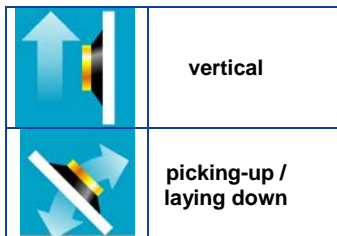
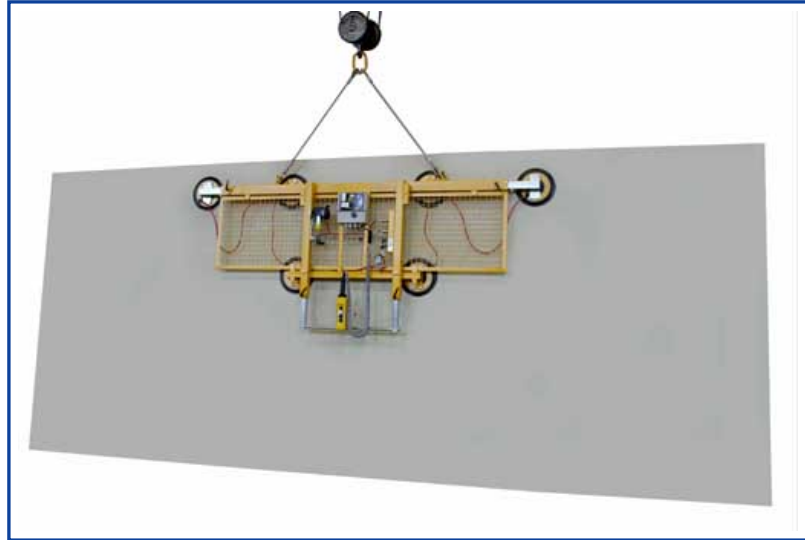

Description

- **1 circuit vacuum system**
- the vacuum circuit has a vacuum tank with nonreturn valve, vacuum switch and control vacuum meter
- **completely closed vacuum circuit**
prevents loss of vacuum at power failure
- acoustic signal indicates insufficient vacuum
- single row arrangement of suction cups
with additional supporting suction cups
- outer suction cup distance adjustable via moving of the carrying bars
- outer suction cups lockable
- vertical transport approx. 85°
- guide handles are adjustable in the height

Vacuum generation

- built-in low maintenance rechargeable battery vacuum pump
(dry running system)
- for battery operation with quick-change device for
short battery change times of less than one minute
- battery charger for charging second battery
- no cable - no hose

Operation

- ON/OFF directly at the device
- SUCTION / RELEASE via remote control

Suspension: 2-fold crane string
Load capacity : **1200 kg**
Colour: yellow / partly zinked

The turnable suspension allows the picking-up/laying down of large sheets (horizontal to vertical/vertical to horizontal).

suitable for lifting				
material properties	gas-tight			
surface	smooth			
e.g.	glass panes, sealed units, window and curtain walling elements, plastic and ceramic plates, coated boards			
suction cup type	388			
diameter in action approx. mm	300			
quality of suction cups	black rubber abrasion possible up to 80° C heat resistant from 4 mm glass thickness			
number of suction cups	6	8	10	12
safe working load on smooth and clean surface at 60 % vacuum				
in-company kg	600	800	1000	1200
outer distance of the suction cups	approx. 3000 – 4000 mm			
dead weight approx. kg				
distribution voltage charger for battery	110 - 230 V / 50/60 Hz / 1 phase			
Item No.: 7011-AB-2012...	-6	-8	-10	-12
Accessories on request				
Item No.: 388-SCHUTZ	protection cap for suction cup 388			
Item No.: 7003-SchutzABs	guard grating (size in accordance to your requirement) at the side			
Item No.: 7003-SchutzABo	guard grating (size in accordance to your requirement) above			
Item No.: 7003-USStAB	support for just sealed units (size in accordance to your requirement)			
Item No.: 7003-FB-SL-1K	radio remote control SUCTION/RELEASE			
Item No.: OPT-388TR	device equipped with : mark-free suction cups for coated glass			
Item No.: OPT-388K	device equipped with : softer suction cup for thinner glass			

