

Kombi 7001-A-1000

**For operation on
EC construction sites only
permissible with mechanical
holding device according to
EN 13155**

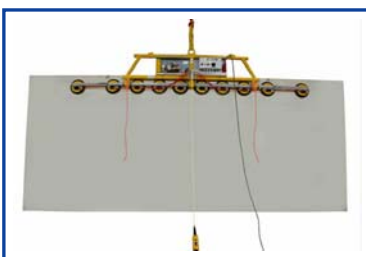

	vertical
	horizontal
	picking-up / laying down

Description

- **1-circuit vacuum system**
- the vacuum circuit has a vacuum tank with nonreturn valve, vacuum switch and control vacuum meter
- **completely closed vacuum circuit**
prevents loss of vacuum at power failure
- warning lamp and acoustic signal indicate insufficient vacuum
- turnable row of suction cups
- fixed distance between the suction cups
- all suction cups lockable individually

Vacuum Generation

- built-in low maintenance vacuum pump (dry running system)
- for operation on power networks

Operation

- ON/OFF directly at the device
- SUCTION/RELEASE via cable remote control
optionally
via radio remote control

Suspension: crane eye at the carrying frame /
2-fold crane string

Load capacity : **400 kg / 1000 kg**
Colour: yellow / partly zinked

suitable for lifting				
material properties	gas-tight			
surface	smooth			
e. g.	glass panes, sealed units, window and curtain walling elements, plastic and ceramic plates, coated boards			
suction cup type	388			
diameter in action approx. mm	300			
quality of suction cups	black rubber abrasion possible up to 80° C heat resistant from 4 mm glass thickness			
number of suction cups	4	6	8	10
safe working load on smooth and clean surface at 60 % vacuum on construction sites outside the EU / in-company kg	400	600	800	1000
outer distance of the suction cup approx. mm	2000 x 300	2500 x 300	3000 x 300	4000 x 300
dead weight approx. kg				
distribution voltage	230 V / 50 Hz / 1 phase			
Item No.: 7001-A-1000-230...	-04	-06	-08	-10
distribution voltage	110 V / 50 Hz / 1 phase			
Item No.: 7001-A-1000-110...	-04	-06	-08	-10
distribution voltage	400 V / 50 Hz / 3 phases			
Item No.: 7001-A-1000-400...	-04	-06	-08	-10
Accessories on request				
Item No.: 388-SCHUTZ	protection cap for suction cup 388			
Item No.: 7003-VLA	set extensions (2 pieces) – approx. 500 mm			
Item No.: 7003-FB-SL-2K	radio remote control SUCTION / RELEASE			
Item No.: OPT-388TR	device equipped with : mark-free suction cups for coated glass			
Item No.: OPT-388K	device equipped with : Softer suction cup for thinner glass			

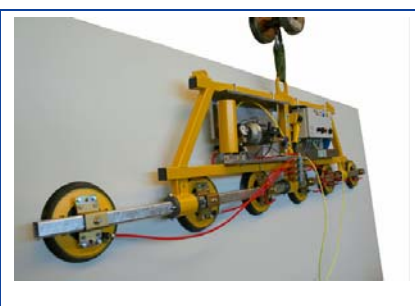
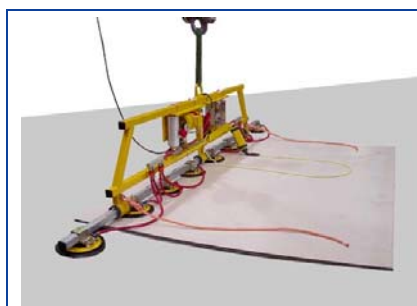

Kombi 7001-A-1000 with 4 suction cups 388

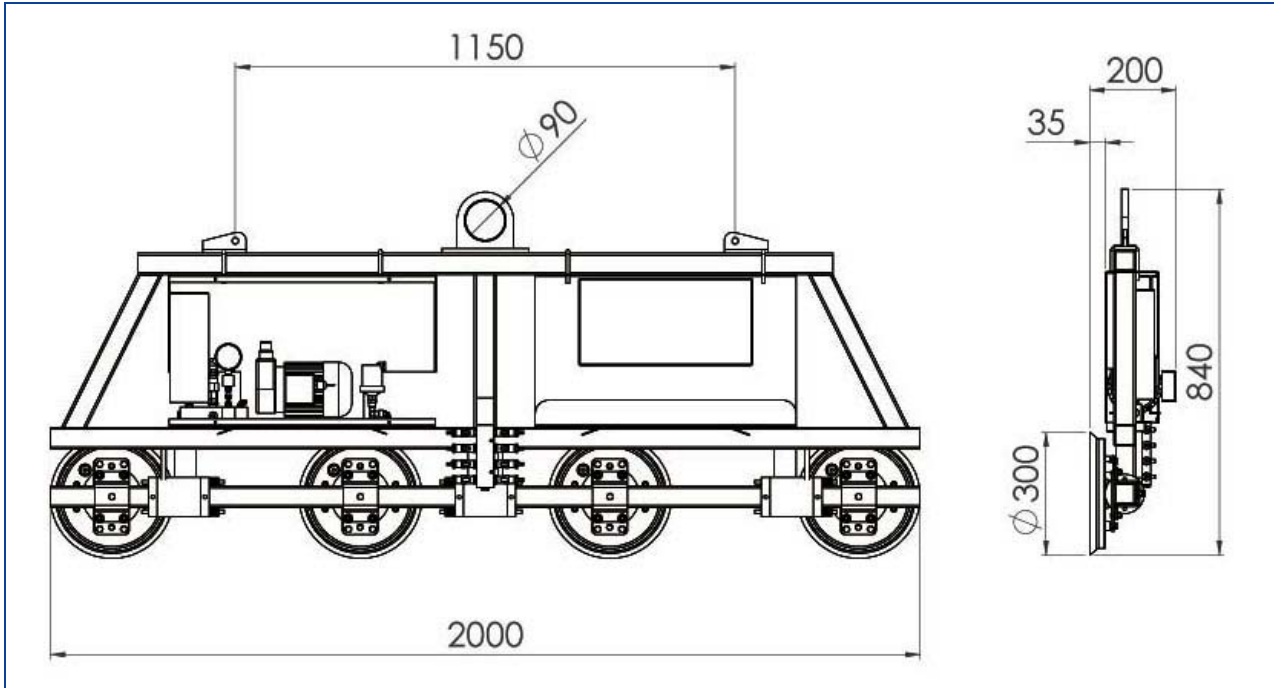

Kombi 7001-A-1000 with 8 suction cups 388

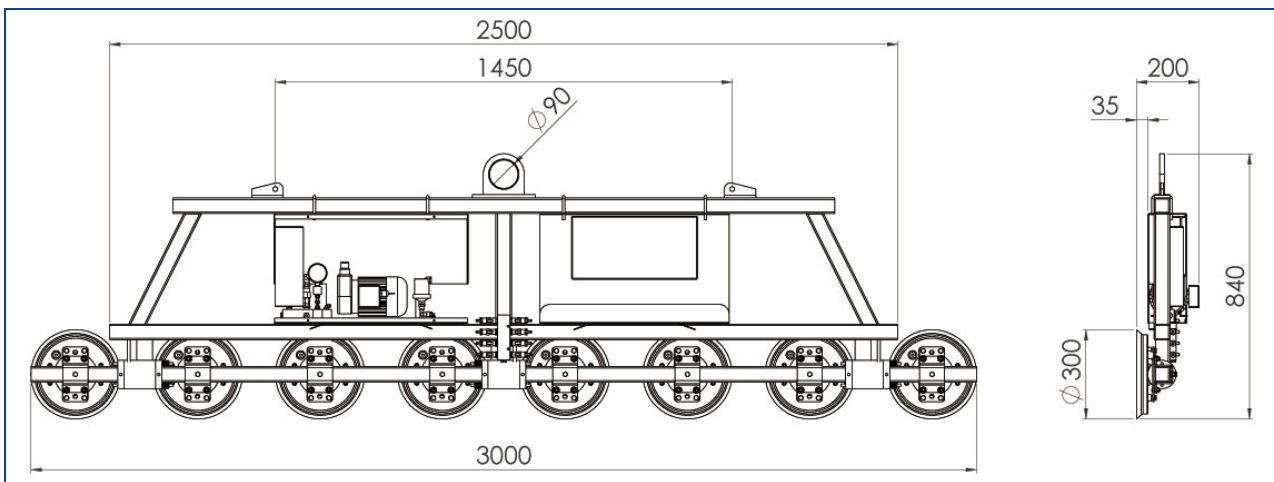

Examples for special solutions
If required, please contact us.

Kombi 7001-A-1000 in shorter version

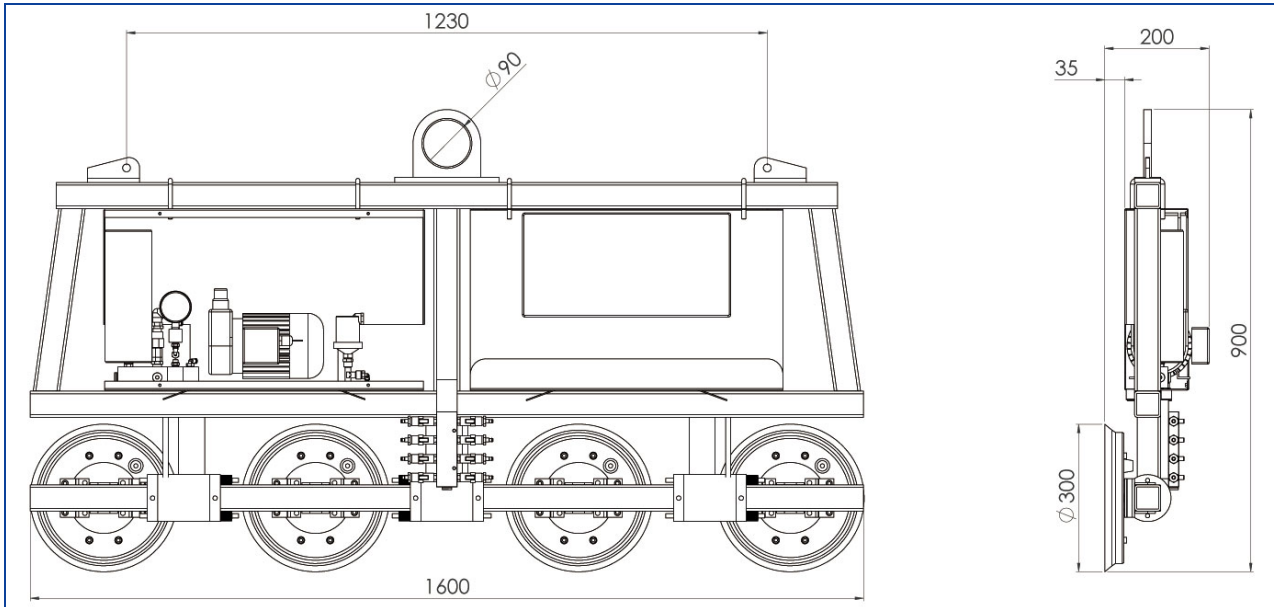

Kombi 7001-A-1000 with 2 extensions

